



water technology

COMPANY WITH QUALITY MANAGEMENT  
SYSTEM CERTIFIED BY DNV  
= ISO 9001:2008 =

**blue**



**blue**  
PROFESSIONAL



EN User and maintenance manual





EN

*The images are indicative only and may not match the actual product.  
Details given here may differ from the actual product.  
Zenit reserves the right to modify the product without prior warning.  
For more information, consult the website [www.zenit.com](http://www.zenit.com).*

## CAUTION



- Installation operations must be carried out by skilled technical staff capable of understanding the contents of the manual.
- Keep out of reach of children.
- Not suitable for unskilled and/or incompetent persons.
- Do not use the electric pump for purposes other than those for which it was designed and manufactured.

## ELECTRIC CONNECTIONS



- Before starting the pump, check that the plug is firmly connected to the socket or the electric connection has been made correctly. The electric system must have a ground connection in good working order.
- If using models with integral float switches, such as the **DRBlue**, take care to turn off the power supply before any cleaning or maintenance procedures to prevent accidental start-ups.
- Do not use the electric pump for lifting flammable or explosive liquids
- Do not allow the free end of the electric cable to come into contact with liquids of any kind
- Never handle or lift the electric pump by the power supply or float switch cables



## SECURITY

- Do not place your hands or objects near and/or insert them in the electric pump's intake or outlet. In particular, be especially careful with **GRBlue** models which have a revolving cutter on the intake side
- Do not swallow or inhale any component of the pump;
- Before performing any cleaning and maintenance procedure, ensure that the electricity supply has been disconnected and wait for the surface of the pump to cool to ambient temperature (at least 30 min.);
- Do not approach the pump when in operation and do not touch the liquid in which it is submerged;
- When handling the electric pump, especially if it has previously been installed, use suitable personal protection equipment such as safety footwear, gloves, goggles and a leather apron or similar protection.

## INTRODUCTION

Before installing and using the pump, read the instructions given below carefully.

There is a self-adhesive label supplied with this manual bearing all the pump data, which must be applied to the manual in the relative space. This manual must be kept for the entire life of the product, as the manufacturer cannot be held responsible for damage, to people or things, caused by the submersible electric pump if used in any other ways than those provided for herein, or in the event that the maintenance and safety regulations are not complied with. In any case, the pump's installation and use must be effected by qualified adults.

## SAFETY

Do not allow the electric pump to be used by children or non-qualified persons.

Do not use the electric pump to decant inflammable fluids.

Do not install the electric pump in confined areas where there may be gas or a risk of explosions.

Do not modify the pump for any reason (such as fitting couplings or carrying out drilling or finishing work, etc...).

Do not put your fingers or other objects in the intake and delivery holes. Be particularly careful when using the **GRBlue** model, which is fitted with a shredder blade in the intake area.

Ensure the end of the electric power cable does not come into contact with the fluid.

When carrying out installation, checking or maintenance operations on the electric pump, always use Personal Protective Equipment (PPE), i.e. regulation garments and equipment.

Accident-prevention shoes and gloves, safety goggles and leather aprons must be always be worn.

Before handling the fitted product, wash it thoroughly with running water.

Only connect the electricity supply once the electric pump has been correctly installed.

Unplug the unit at the mains before carrying out any maintenance and/or cleaning operations or when simply removing the pump from the fluid.

Use jets of water and/ or detergent to clean the machine before carrying out any maintenance and/ or cleaning operation.

Do not obstruct the fluid intake and delivery pipes.

In the event of damage, stop the pump immediately.

Contact an authorised Zenit technical service centre for repairs and always request the use of original spare parts.

Failure to comply with the above could result in impaired pump safety, in addition to forfeiture of the warranty.

## CONDITIONS OF USE

Electric pumps not suitable for fluids for alimentary use.

The **DRBlue**, **DGBBlue**, **GRBlue**, **APBlue** model electric pumps are designed to treat fluids such as clear water, dirty water or sewage.

The electric pump normally works completely immersed in the fluid in order to prime itself and to pump out.

The pump must be immersed completely in the fluid so that the latter can cool the motor sufficiently. This way the inlet will not take in air and the pump will operate correctly.

The motor can be allowed to run uncovered very briefly.

In the **DRBlue** versions the intake strainer can be removed by skilled technical staff to enable fluid intake from up to the last few millimetres from the bottom.

In any situation in which the pump cannot be completely immersed the utmost care must be taken to ensure the motor does not overheat.

The **DRBlue** and **APBlue** models are designed for the evacuation of clear water or dirty water containing small solid bodies.

The **DGBBlue** model guarantees a clear passage for solids of up to 50 mm and is suitable for the treatment of dirty water.

The **GRBlue** model can be used for sewage containing fibres which can be shredded using an intake shredding system.

Number of start-ups per hour: A maximum of 20 evenly spaced start-ups (for the **GRBlue** there is a risk of breakage of the condenser if the unit is started up too many times within a short period).

Immersion depth: maximum of 20m beneath the fluid level

Temperature of fluid treated: maximum of 40°C, or 60° with discontinuous operation.

Density of fluid treated: maximum of 1.1 Kg/ dm<sup>3</sup>

PH of fluid to be pumped: between 6 and 14.

If the electric pump is used in swimming pools and suchlike, people must not bath in or come into contact with the treated fluid until the pump has been removed from the pool.

Users must follow the safety rules in force in the country of use, as well as applying their common sense, and make sure the routine cleaning and maintenance operations are carried out correctly.

It is the installer's duty to check the correct environmental conditions for use of the pump, ensuring they guarantee safety and hygiene.

The responsibilities of the staff authorised to use the electric pump are delegated to the customer.

## NOISE LEVEL

The submersible electric pumps feature an acoustic pressure level of below 70dB(A) when immersed and below 80dB(A) in the air.

## HANDLING

The electric pumps of 30 kg or less can be handled and lifted manu-

ally using the special handle located in the upper section of the pump. Do not use the electric power cable or the floating switch cable to lift or move the pump.

Check that the box and its contents are in perfect condition and stop the installation in the event that any defects or anomalies are found, then inform the supplier.

### INSTALLATION

If the pump is installed inside a shaft, this must be large enough to allow the floating switch, if installed, to move freely. The manufacturer recommends the use of shafts which are no smaller than 500mm x 500mm x 500mm. (Fig. 1)

**WARNING:** Check that the submersible pump has been primed. In some cases, an air bubble may form in the upper part of the pump body, which prevents liquid pumping.

**WARNING:** Before the installation and/or the start-up of the pump after a long period of inactivity, turn the shaft with the box wrench to ensure that it rotates freely.

**Mobile post (Fig. 2):** using a hose union, connect the delivery pipe to a hose with an internal reinforcement coil and a diameter which is the same size as or larger than the electric pump outlet.

**Fixed post (Fig. 3):** connect the electric pump to a metal piping, fitting a non-return valve and an interception gate valve on the said metal piping.

This ensures the pump stability is guaranteed by the piping.

The pump can also be connected to polyethylene piping, using the relative union.

Secure the hose to the union by means of a metal band clamp.

**With the joining foot (Figs. 4-5):** Fix the joining foot to the bottom of the tank first, using expansion plugs. Install the delivery pipe with the relative non-return valve and gate valve.

Engage two guidepipes on the joining foot, fixing them in the upper part using the spacer bracket provided by Zenit with the joining foot.

This way, the pump can be lowered supported with a chain or cable hooked around the handle and, thanks to the two guide pipes it will fit perfectly in place on the foot.

### ELECTRICAL CONNECTIONS (Figs. 8-9)

All the operations involved in the connection to the electrical network must be carried out by skilled labour and in compliance with the legislation in force.

**ATTENTION:** In the wiring-up stage, connect the yellow-green earth conductor first, then the others.

For the protection of the electric motor and the safety of the people in the vicinity, connect the pump to a suitably-scaled differential overload switch.

**CAUTION:** pumps may be fitted with automatically-resetting thermal protection which prevents them from breaking in the event of overheating; So the pump cooling starts again automatically.

Before installation make sure that:

- the power line has an earth and complies with the regulations in force
- the pump's and float switch cables are not damaged

Before making the three-phase electrical connection, make sure the rotation direction is correct.

To check the rotation direction, proceed as follows:

- Take the precautions specified in the manual
- lay the pump horizontal on one side and leave it free
- temporarily connect the yellow-green wire to ground and then connect the power supply wires to the contactor;
- make sure there are no people or objects within a radius of at least 1 metre of the pump;
- turn on the start switch for a few moments;
- watch the impeller as it stops through the intake port and check that it turns anticlockwise.

If the pump is rotating in the wrong direction, invert two of the power supply wires in the contactor and try again.

Once the correct rotation direction has been obtained, MARK the pow-

er supply wire connection positions, REMOVE the temporary electrical connections and install the pump in the planned position.

### FLOATING SWITCH

The electric pump can be supplied with a floating switch and its functioning is completely automatic. Make sure that there is nothing around that could obstruct the movement.

It is important that the cables do not get in each other's way, twisted up or stuck in any jutting parts or grips inside the tank (Fig. 6).

The floating switch has an adjustable stroke to allow regulation of the on and off levels. Make sure that the minimum level does not fall below the pump's upper shield (Fig. 7).

### RESIDUAL RISKS

The risks that cannot be eliminated by the safety measure adopted by the manufacturer are caused by incorrect use of the pump or by the user's failure to comply with the safety regulations described in this manual. In particular, the user must ensure no people and/or animals come into contact with the fluid when the pump is working.

### MAINTENANCE

The pump maintenance and repair operations must be carried out by workers authorised by the manufacturer; Failure to comply with these instructions will result in forfeiture of the warranty and jeopardise the unit's safety.

Before any cleaning and/ or maintenance operations are carried out on the electric pump, the power supply must be switched.

To disconnect the submersible electric pump from the electricity mains, first disconnect the phase conductors, then the yellow –green earth one.

Use the special handle to remove the submersible electric pump from the tank.

**ATTENTION:** Before carrying out any operations, check the pump temperature.

Only work on the pump when it is at room temperature.

Clean the electric pump thoroughly, using a jet of water or specific products to clean all its parts. When disposing of the waste material, follow the antipollution rules in force.

Replace any broken or worn parts with original spare parts only.

Given the likelihood that work on the electric pump will be carried out in confined spaces such as vats, wells, cesspools, tanks or cisterns, do not underestimate the risks caused by potentially poisonous exhalations.

### SCRAPPING

Store the electric pump in a suitable place, out of reach of children and unauthorised persons.

Dispatch the electric pump to an authorised scrapping centre for its disposal.

Do not dump any parts of the electric pump.



500x500x500 mm MIN

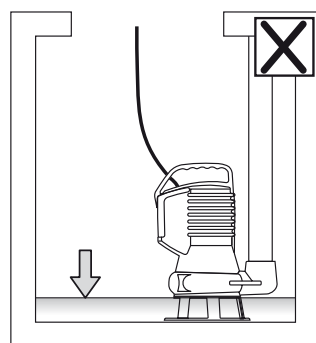
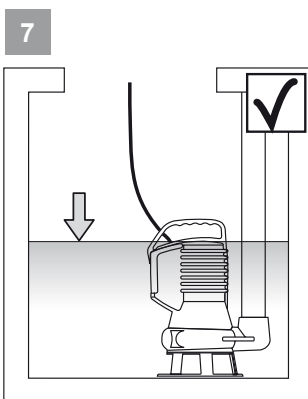
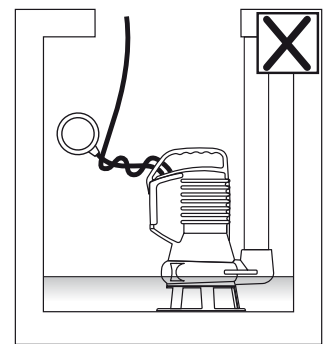
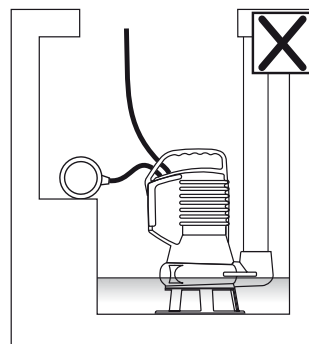
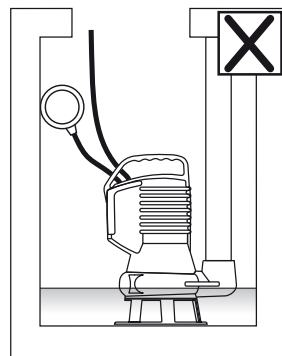

EN

ELECTRICAL CONNECTIONS

8 ~1 50/60Hz

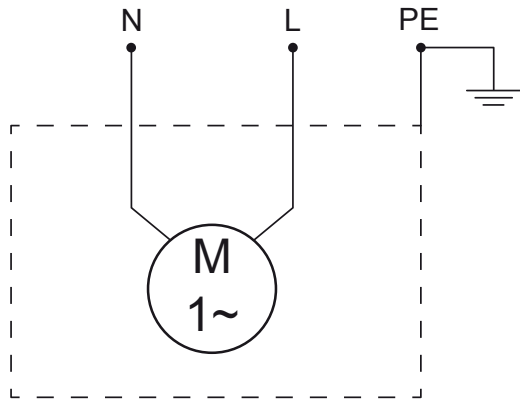

9 ~3 50/60Hz

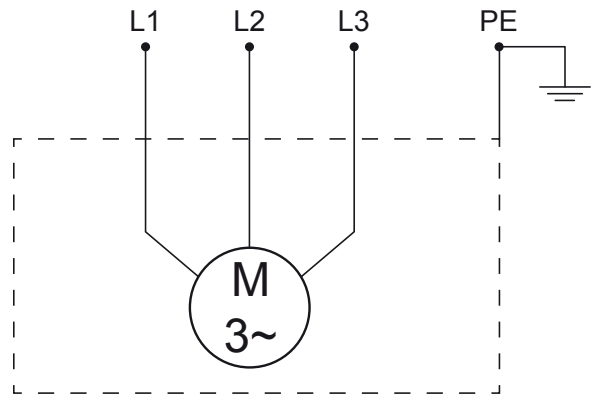

	<b>L - N</b>	<b>L1 - L2 - L3</b>	<b>PE</b>
<b>EN</b>	Single-phase power supply	Three-phase power supply	Ground

**EN OVERALL DIMENSIONS**

# DGblue



	A mm	B mm	C mm	D mm	E	F mm	kg
DG Blue 40/2/G40V A1BM/50(60)	265	115	335	140	G 1½"	190	12.5
DG Blue 50/2/G40V A1BM/50(60)	265	115	335	140	G 1½"	190	13
DG Blue 75/2/G40V A1BM/50(60)	265	115	335	140	G 1½"	190	15
DG Blue 100/2/G40V A1BM/50(60)	265	115	335	140	G 1½"	190	15.5

# DGblue PROFESSIONAL



	A mm	B mm	C mm	D mm	E	F mm	kg
DG BluePRO 50/2/G40V A1BM(T)/50(60)	265	115	335	140	G 1½"	190	13
DG BluePRO 75/2/G40V A1BM(T)/50(60)	265	115	335	140	G 1½"	190	15
DG BluePRO 100/2/G40V A1BM(T)/50(60)	265	115	335	140	G 1½"	190	15.5
DG BluePRO 150/2/G50V A1CM(T)/50(60)	295	125	465	195	G 2"	200	23
DG BluePRO 200/2/G50V A1CM(T)/50(60)	295	125	465	195	G 2"	200	24

# DRblue



	A mm	B mm	C mm	D mm	E	F mm	kg
DR Blue 40/2/G32V A1BM/50(60)	255	115	295	110	G 1¼"	150	11.5
DR Blue 50/2/G32V A1BM/50(60)	255	115	295	110	G 1¼"	150	12
DR Blue 75/2/G32V A1BM/50(60)	255	115	295	110	G 1¼"	150	13.5
DR Blue 100/2/G32V A1BM/50(60)	255	115	295	110	G 1¼"	150	15.5

# DRblue PROFESSIONAL



	A mm	B mm	C mm	D mm	E	F mm	kg
DR BluePRO 50/2/G32V A1BM(T)/50(60)	255	115	295	110	G 1¼"	150	12
DR BluePRO 75/2/G32V A1BM(T)/50(60)	255	115	295	110	G 1¼"	150	13.5
DR BluePRO 100/2/G32V A1BM(T)/50(60)	255	115	295	110	G 1¼"	150	14
DR BluePRO 150/2/G50V A1CM(T)/50(60)	295	125	420	170	G 2"	200	23
DR BluePRO 200/2/G50V A1CM(T)/50(60)	295	125	420	170	G 2"	200	24



**GRblue**  
PROFESSIONAL



	A mm	B mm	C mm	D mm	E	F mm	kg
GR BluePRO 100/2/G40H A1CM(T)/50(60)	270	130	365	95	G 1½"	220	19
GR BluePRO 150/2/G40H A1CM(T)/50(60)	285	125	410	100	G 1½"	230	24
GR BluePRO 200/2/G40H A1CM(T)/50(60)	285	125	410	100	G 1½"	230	25

**APblue**  
PROFESSIONAL

**APblue HP**  
PROFESSIONAL



	A mm	B mm	C mm	D mm	E	F mm	kg
AP BluePRO 100/2/G40H A1CM(T)/50(60)	270	130	365	95	G 1½"	220	19
AP BluePRO 150/2/G40H A1CM(T)/50(60)	285	125	410	100	G 1½"	230	24
AP BluePRO 200/2/G40H A1CM(T)/50(60)	285	125	410	100	G 1½"	230	26

	A mm	B mm	C mm	D mm	E	F mm	kg
AP BluePRO HP 150/2/G40H A1CM(T)/50(60)	285	125	410	100	G 1½"	230	24

EN

MAIN COMPONENTS

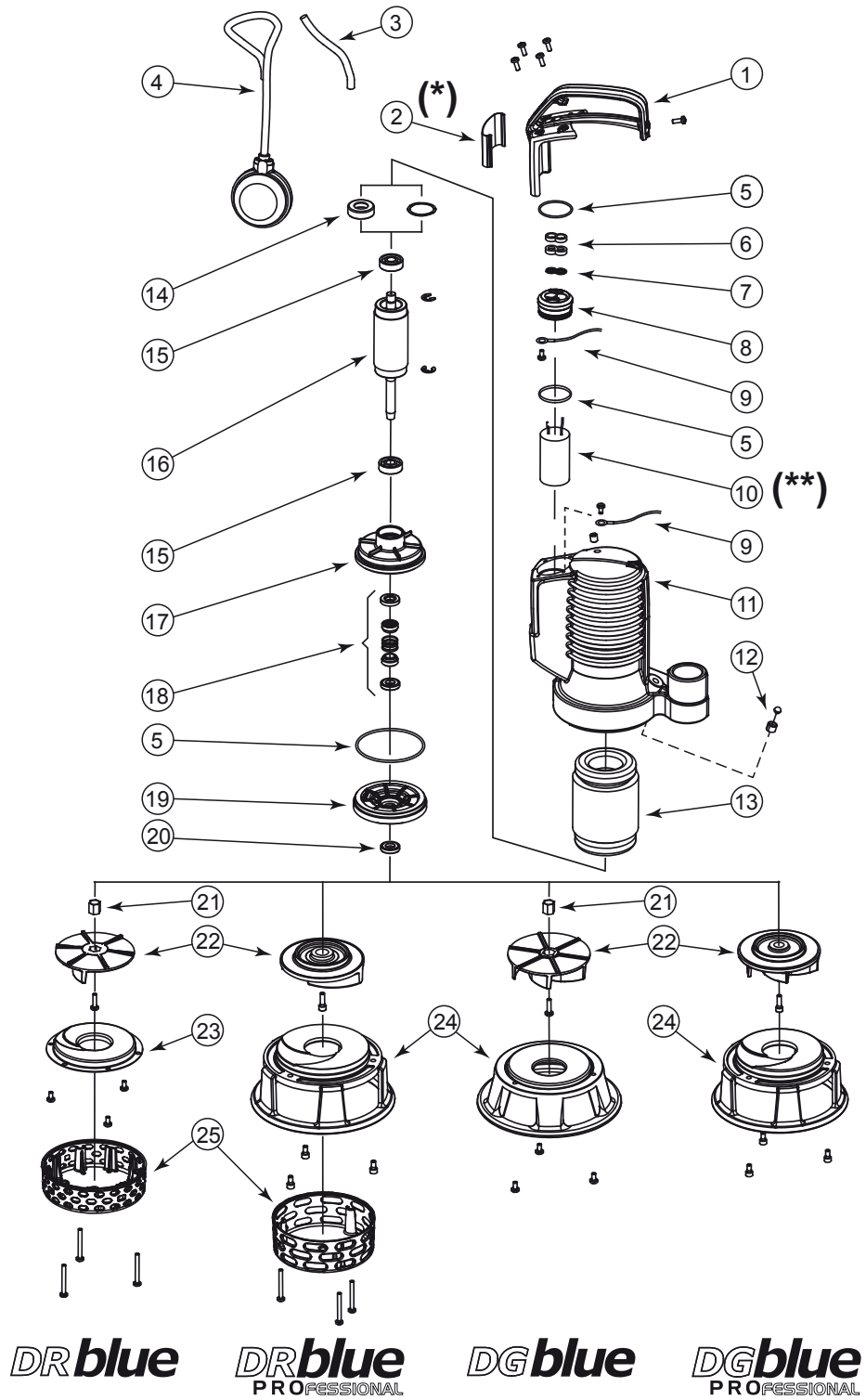

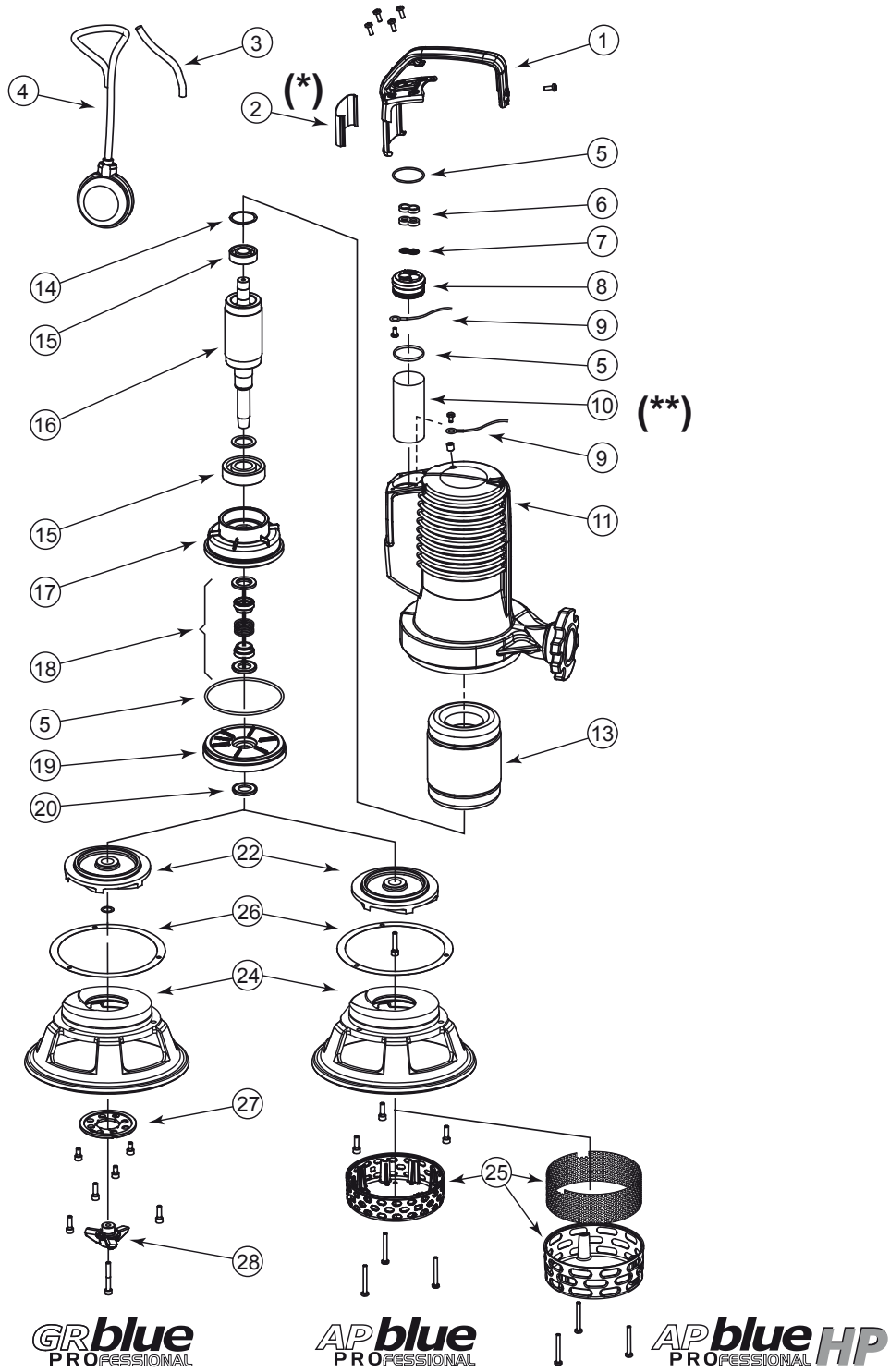

EN (\*) PROFESSIONAL LINE only  
 (\*\*) single-phase models only

	EN
1	Handle
2	Plate (*)
3	Cable
4	Float switch (**)
5	O-Ring
6	Cable gland system
7	Cable fastener
8	Cable gland support
9	Ground
10	Capacitor(**)
11	Motor case
12	Bleeder valve(*)
13	Stator
14	Rubber boot / Support washer
15	Bearing
16	Shaft with rotor
17	Lower bearing holder
18	Mechanical seal
19	Oil chamber sealing flange
20	V-Ring
21	Impeller bushing
22	Impeller
23	Suction flange
24	Base
25	Grid
26	Gasket
27	Cutting disk
28	Cutter

EN (\*) PROFESSIONAL LINE only  
 (\*\*) single-phase models only





water technology

[www.zenit.com](http://www.zenit.com)

Rev. 2 - 01/07/14